

Starrett®

PKG08823 - UMFMS

TRUST IS IN THE NAME

User Manual

READ THIS MANUAL BEFORE USING THE INSTRUMENT

**ANTES DE UTILIZAR EL INSTRUMENTO,
LEA ATENTAMENTE ESTE MANUAL**

LIRE CE MANUEL AVANT D'UTILISER L'INSTRUMENT

**LEIA ATENTAMENTE ESTE MANUAL ANTES
DE UTILIZAR O INSTRUMENTO**

使用仪器前请阅读本操作手册

**DIESES HANDBUCH VOR DER VERWENDUNG
DES MESSGERÄTS LESEN**

**LEGGERE ATTENTAMENTE QUESTO MANUALE PRIMA
DI UTILIZZARE QUESTO STRUMENTO**

Starrett®

FMS TEST FRAME FOR FORCE MEASUREMENT USER'S GUIDE

TABLE OF CONTENTS

	PAGE		PAGE
	5	6.3	L2 Controller 19
	5	6.4	Test Fixtures 19
1.0	Introduction 8	7.0	Operation 20
1.1	System Description 8	7.1	System Startup 20
1.2	System Safety and Labeling 8	7.2	Setting Crosshead Travel Limits 20
1.3	Product Support 8	7.3	Setting Grip Protection 21
1.4	Calibration and Verification 8	7.4	Load Cell Protection 21
2.0	Specifications 9	7.5	Starting a Test 22
2.1	Common Specifications 10	7.6	Stopping a Test 22
2.1.1	Power 10	7.6.1	Emergency Stopping 22
2.1.2	Fuse Rating 10	7.6.2	Using Start/Stop Button 22
2.1.3	Weight 10	7.6.3	Using Start/Stop Target 22
2.1.4	Noise 10	8.0	Maintenance 23
2.1.5	Environmental 10	8.1	Preventive Maintenance 23
2.1.6	Measurement Accuracies 10	8.1.1	Daily Maintenance Checks 23
3.0	Lifting and Handling 10	8.1.2	Authorized Factory Maintenance 23
3.1	General Precautions 10	8.1.3	Cleaning 23
3.2	Unpacking Your System 11	8.1.4	Lubrication 23
3.3	Positioning Your System for Use 11	8.2	Maintenance Procedures 23
4.0	Installation 11	8.2.1	Travel Limits 23
4.1	Customer Responsibilities 11	8.2.2	Emergency Stop 24
4.2	Starrett Responsibilities 11	8.2.3	Fuse Replacement 24
4.3	Site Considerations 12		
4.4	Input Power 12		
4.5	Connecting System Components 12		
4.5.1	Installing the L2 Controller 12		
4.5.2	Installing Base Clevis Assembly 13		
4.5.3	Installing FLC Load Cell Sensor 13		
4.5.4	Installing Load Cell Clevis Assembly 13		
4.5.5	Installing Testing Fixture 14		
4.6	Installing Anti-skid Mounting Clips 14		
5.0	System Controls 15		
5.1	FMS Test Frame 15		
5.1.1	Emergency Stop Switch 15		
5.1.2	Power Switch 15		
5.1.3	Jog Switch 15		
5.1.4	Test Start/Stop Switch 16		
5.1.5	Travel Limit Switches 16		
5.2	L2 Controller 16		
5.2.1	Power Switch 16		
5.2.2	Start/Stop Target 17		
6.0	Using Your FMS System 18		
6.1	FLC Load Cell Sensors 18		
6.2	Pinch Load 19		

GENERAL SAFETY PRECAUTIONS

Force measurement systems are potentially hazardous. Prior to operating your testing system, Starrett recommends that you read and understand the instruction manuals for your system and components and that you receive training on the proper use of this equipment from your authorized Starrett representative.

Observe all warnings and cautions identified in this manual for your equipment. A warning identifies a function that may lead to injury or death. A caution identifies a hazard that may lead to damage to equipment or loss of data.

Starrett products, to the best of our knowledge, comply with various national and international safety standards as they apply to material and force measurement testing. This Starrett product has been tested and found to comply with the following recognized standards:

CONFORMANCE

LOW VOLTAGE DIRECTIVE

- EN 61010-1: 2001 Safety requirements for electrical equipment for measurement, control and laboratory use

EMC EMISSIONS

- ICES-003 Issue 4 Class A Digital Apparatus Emissions Requirements (Canada)
- CFR 47 FCC Part 15 Subpart B Class A Emissions Requirements (USA)
- EN 55011:2007/A2:2007 Group 1 Class A ISM Emissions Requirements (EU)

EMC EMISSION AND IMMUNITY

- EN 61326:2006 EMC requirements for electrical equipment for measurement, control and laboratory use – Industrial Use

Starrett also certifies that this product complies with all relevant EU directives and carries the CE mark.

ELECTROMAGNETIC COMPATIBILITY

Your FMS Series force measurement system is designed to comply with International Electromagnetic Compliance (IEC) standards.

To ensure reproduction of this EMC performance, connect this equipment to a low impedance ground connection. Typical suitable connections are a ground spike or the steel frame of a building.

WARNINGS

EMERGENCY STOP

Press the emergency stop button whenever you feel there is an unsafe condition during a test. The emergency stop button removes power to the motor drive system causing the crosshead to stop.

FLYING DEBRIS

Eye protection, protective clothing and splinter/safety shields should be used whenever any possibility exists of a hazard from the failure of a sample, assembly or structure under test. Due to the wide range of materials that may be tested and that may result in a failure which may cause bodily injury, the precautions and preventative methods taken prior to testing is entirely the responsibility of the owner and the user of the equipment.

CRUSH HAZARD

Always use caution when installing or removing apparatus and your sample material between the frame's crosshead and the base. A potential pinch/crush hazard exists. Keep clear of the testing fixture, and particularly the jaw faces at all times. Keep clear of the crosshead during movement. If available, always make sure the Pinch Load feature is enabled. This will stop inadvertent crosshead operation if in manual mode. Always ensure that other personnel cannot operate the system while you are working within the test fixture area.

ELECTRICAL HAZARD

Disconnect equipment from the electrical power supply before removing any electrical safety covers. Disconnect power when replacing fuses. Never reconnect power while the covers are removed. Never operate the system with protective covers removed.

ROTATING MACHINERY HAZARD

Always disconnect power before removing covers that protect the user from the internal rotating mechanisms. If maintenance to the drive mechanism is required, and power is needed to perform maintenance to the drive system, maintenance should be performed by an authorized Starrett representative who has received factory training on performing such procedures.

PRODUCT WARRANTY

Starrett force measurement products carry a one-year (from date of purchase) warranty against defects in material and workmanship (parts and labor), subject to factory inspection.

The L.S. Starrett Company will repair or replace, at its option, any part or parts found to be defective in workmanship or material. Starrett warrants repaired or replaced parts for the balance of the original warranty period or 90 days, whichever is longer. Parts returned to the factory under warranty will be repaired at no charge. Freight charges to the factory will be paid by the customer. Return freight charges to the customer will be paid by Starrett.

This warranty does not cover damages from such causes as abuse, accident, neglect, fire or freight damage. It does not apply to defects resulting from modifications made by the customer or improper use of the system or its components.

DISCLAIMER OF LIABILITIES

The L.S. Starrett Company shall have no liability or responsibility to the customer or any other person or entity with respect to any liability, loss or damage caused or alleged to be caused directly or indirectly by this documentation, or the hardware

described in it. This includes but is not limited to any interruption of service, loss of business or anticipatory profits, or consequential damages resulting from the use or operation of hardware or equipment.

FMS TEST FRAME FOR FORCE MEASUREMENT USER'S GUIDE



**THIS IS A STARRETT USER GUIDE FOR THE FMS TEST FRAME.
ALL SPECIFICATIONS IN THIS DOCUMENT ARE CORRECT AT TIME OF
PRODUCTION AND ARE SUBJECT TO CHANGE. PLEASE CONTACT STARRETT
FOR FURTHER INFORMATION.**

1.0 INTRODUCTION

Thank you and congratulations for selecting the FMS for your force measurement testing.

Your FMS testing system may be used for tension and compression testing including specific test methods such as peak, break, constant hold, flexural, shear, peel, coefficient of friction and more. Your FMS testing system should be used with Starrett equipment and accessories only. And for optimum performance, your FMS testing system should be maintained and serviced annually by an authorized Starrett representative.

1.1 SYSTEM DESCRIPTION

Your FMS system consists of the testing frame, L2 digital controller, load cell sensors and test fixtures. Together, these components provide you with a full-featured testing system for most force measurement testing applications.

1.2 SYSTEM SAFETY AND LABELING

ISO and ANSI safety labels are affixed to Starrett equipment to alert users and operators of the equipment to warnings and cautions. System users should obey all warnings and cautions and should be trained on the safe operation of this equipment by an authorized Starrett representative.

1.3 PRODUCT SUPPORT

If you ever require product support for your Starrett system, contact your authorized Starrett representative. Authorized Starrett representatives are listed on our website at www.starrett.com. In the event that your Starrett representative may not be able to assist you, contact Starrett at one of our many international sales offices. Our sales offices are listed on our website at www.starrett.com.

1.4 CALIBRATION AND VERIFICATION

Your FMS System is calibrated and tested at our factory prior to shipment to you. Our factory calibrations are traceable to national standards. If you require an ASTM E4 or ISO 7500-1 calibration, Starrett or a Starrett authorized representative can perform a calibration on-site in order to comply with these international calibration standards.

Starrett recommends that you calibrate your system at least annually. More frequently calibrations may be required depending on the frequency of which the system is used. If your system is calibrated to ASTM E4 or ISO 7500-1, it must be calibrated whenever the system is relocated, e.g. moved from its location where the previous calibration occurred.



2.0 SPECIFICATIONS



SPECIFICATION	FMS500	FMS1000	FMS2500	FMS5000
Load Capacity	500N 112lbf 50kgf	1000N 225lbf 100kgf	2500N 562lbf 250kgf	5000N 1124lbf 500kgf
Maximum Crosshead Speed	50 in/min 1270 mm/min	50 in/min 1270 mm/min	50 in/min 1270 mm/min	50 in/min 1270 mm/min
Minimum Crosshead Speed	0.001 in/min 0.02 mm/min	0.001 in/min 0.02 mm/min	0.001 in/min 0.02 mm/min	0.001 in/min 0.02 mm/min
Speed Accuracy	±0.2% of set speed	±0.2% of set speed	±0.2% of set speed	±0.2% of set speed
Distance Accuracy (no load)	Better than 0.02%	Better than 0.02%	Better than 0.02%	Better than 0.02%
Crosshead Travel	15 in 381 mm	30 in 762 mm	40 in 1016 mm	40 in 1016 mm
Throat Depth	4.25 in 108 mm	4.25 in 108 mm	4.25 in 108 mm	4.25 in 108 mm
Height	32 in 813 mm	50 in 1270 mm	62 in 1575 mm	62 in 1575 mm
Width	15 in 381 mm	15 in 381 mm	15 in 381 mm	15 in 381 mm
Depth	20.25 in 514 mm	20.25 in 514 mm	20.25 in 514 mm	20.25 in 514 mm
Weight	135 lbs 61 kg	170 lbs 77 kg	195 lbs 88 kg	195 lbs 88 kg
Input Voltage	100 - 240Vac	100 - 240Vac	100 - 240Vac	100 - 240Vac
Fuse	3.15A Slo-Blo 5 x 20mm (2ea.)	3.15A Slo-Blo 5 x 20mm (2ea.)	6.35A Slo-Blo 5 x 20mm (2ea.)	6.35A Slo-Blo 5 x 20mm (2ea.)
Input Frequency	50 - 60Hz	50 - 60Hz	50 - 60Hz	50 - 60Hz
Operating Temp	+50° to +100°F +10° to +38°C	+50° to +100°F +10° to +38°C	+50° to +100°F +10° to +38°C	+50° to +100°F +10° to +38°C
Storage Temp	-40° to +150°F -40° to +66°C	-40° to +150°F -40° to +66°C	-40° to +150°F -40° to +66°C	-40° to +150°F -40° to +66°C
Humidity Range	+10% to +90%, non-condensing	+10% to +90%, non-condensing	+10% to +90%, non-condensing	+10% to +90%, non-condensing
CE Compliant	Yes	Yes	Yes	Yes

2.1 COMMON SPECIFICATIONS

The common specifications for all FMS Series frames are described in the following sections.

2.1.1 POWER

FMS frames feature a self-regulating power input module. There is no need to adjust your system with jumpers or voltage regulators based on the source input power.

FMS frames are single phase voltage instruments capable of support source power at 100, 120, 220 and 240Vac $\pm 10\%$. Frequency is 47 to 63 Hz.

2.1.2 FUSE RATING

All FMS frames require two (2) Slo-Blo type fuse per the information in the following table.

TABLE 2.1 - FMS FUSE RATING

FMS MODEL	FUSE RATING	SIZE	QTY
FMS500	250V 3.15A Slo-Blo	5 x 20mm	2
FMS1000	250V 3.15A Slo-Blo	5 x 20mm	2
FMS2500	250V 3.15A Slo-Blo	5 x 20mm	2
FMS5000	250V 6.3A Slo-Blo	5 x 20mm	2

2.1.3 WEIGHT

FMS frames are heavy due to their construction to minimize deflection and maximize stiffness. The weights shown in Table 2.1 are frame weights only.

WARNING

Starrett recommends that at least two (2) adults be used to lift an FMS frame. Do NOT use fork lift equipment to lift an FMS frame since the forks may damage the granite base.

TABLE 2.1 - FMS FRAME WEIGHT

FMS MODEL	POUNDS (LBS)	KILOGRAMS (KG)
FMS500	135 lbs	61 kg
FMS1000	170 lbs	77 kg
FMS2500	195 lbs	88 kg
FMS5000	195 lbs	88 kg

2.1.4 NOISE

The FMS frames are designed to limit noise produced by the frame to less than 70dB(A).

2.1.5 ENVIRONMENTAL

The following environmental specifications are common to all FMS frames.

PARAMETER	SPECIFICATION
Operating Temperature	+50° to +100°F +10° to +38°C
Storage Temperature	-40° to +150°F -40° to +66°C
Humidity	+10% to +90%, non-condensing
Environmental Conditions	Designed for use under normal laboratory conditions. Protective measures may be required if location is subject to excessive dust, corrosive fumes, electromagnetic fields or hazardous conditions.

2.1.6 MEASUREMENT ACCURACIES

The measurement accuracies for all FMS systems are shown in the table below.

PARAMETER	ACCURACY
FLC Sensor Load Accuracy	$\pm 0.1\%$ Full Scale
FMS Frame Speed Accuracy	$\pm 0.2\%$ of set speed
FMS Frame Distance Accuracy	Better than 0.02% Full Scale (No Load)

3.0 LIFTING AND HANDLING

Your FMS force measurement system is packed in a sturdy plywood crate. The protective crate is environmentally friendly and assembled with clamps that secure the walls together without screws. Clamps may be removed with the special clamping tool supplied or using a screw driver.

Your FMS system is intended to be used on a table or work bench. Make sure the table or work bench has sufficient strength to support the weight of the testing frame.

Before you locate your frame, please ensure the following:

- Read the section Site Considerations. Verify that all conditions are met prior to transporting and locating your frame.
- Your equipment operators are trained and appropriately licensed (if necessary) to your local safety standards.
- At the location where your frame is to be established, there is sufficient ceiling clearance from the top of the frame.
- You have adequate protective materials to protect your frame when moving to its intended site.

3.1 GENERAL PRECAUTIONS

WARNING

Your FMS frame is heavy. Use at least two adults to lift the frame.

CAUTION

Be careful to not put any strain on the Emergency Stop or other controls located on the front panel of your system. Make sure the crosshead travel limits are clear and free from becoming entangled during lifting.

3.2 UNPACKING YOUR SYSTEM

The crate used to package your system uses compression clips that secure the top and side walls to the base. Use caution when removing these clips since they are under compression force.

WARNING

The crate's top and walls are secured in place using compression clamps. When unsnapping these clamps place one hand over the clamp as you remove the clamp from its groove. This will prevent the clamp from becoming air borne.

- Remove the clamps that secure the top of the crate first.
- Remove the top cap. Leave the foam insert in place.
- Remove the right-hand side clamps. Exercise caution since the side clamps secure both the side and front and back side of the crate.
- Remove the left-hand side clamps. Remove the side walls to the crate.
- Remove the foam inserts.
- Remove the Accessory boxes.

NOTE

Save the crate in case you need to store or ship your FMS frame at a later date.

3.3 POSITIONING YOUR SYSTEM FOR USE

Using at least two (2) adults, firmly grasp the frame base. Lift the frame off of the base of the crate. Place the frame on to its operating position.

4.0 INSTALLATION

This section will provide you with installation guidelines for your FMS force measurement system. Starrett recommends that your authorized Starrett Representative be responsible for installing and commissioning your system at your location.

NOTE

Starrett recommends that your authorized Starrett Representative installs and commissions your FMS force measurement system.

4.1 CUSTOMER RESPONSIBILITIES

As the customer for this product, you are responsible for:

- Insurance and safety responsibilities during installation and operation of this precision instrument.
- Arrange to off-load and unpack the equipment using qualified personnel or an authorized Starrett Representative.
- Transportation of the equipment to its intended test location. This includes responsibility for any special handling or rigging considerations.
- Preparation of the test site including the physical, electrical and environmental considerations.
- Proper disposal of any waste materials generated from the installation.

4.2 STARRETT RESPONSIBILITIES

Starrett recommends that an authorized Starrett Representative take responsibility for the unpacking, siting, installation and commissioning of your FMS force measurement system.

Starrett or an authorized Starrett Representative will:

- Install the machine, its components and any additional accessories that were purchased from Starrett or your Starrett Dealer.

IMPORTANT

The customer must NOT attempt to install the machine without a Starrett Representative present.

- Perform an initial operation of the system and a verification check to ensure that the system is working properly and measuring accurately.
- Perform a customer demonstration that describes how to operate the system.

IMPORTANT

Starrett recommends that customers purchase a one-day hands-on training session for all customer personnel who will operate the equipment.

- Supply documentation on the operation of the system including manuals and user guides.

4.3 SITE CONSIDERATIONS

Proper site preparation is important to ensure that your FMS force measurement system operates in accordance to its published specifications. Customer should consider the following prior to installation and siting of your equipment:

- Ensure that the work table or bench where the system is to be placed onto has sufficient strength to carry the weight of the testing frame and all of its connected components. A table with leveling feet is preferred.
- Ensure that the table top can make use of optional anti-skid clips if required. Skid clips are bolted to the table therefore the table material should allow for drilling holes and attaching screws or bolts. Anti-skid clips are not required, but may be recommended for certain types of tests.
- The frame is not located against a wall or other object that may interfere with air ventilation around the frame base and column. Proper air ventilation is required to dissipate the heat generated from the internal components and motor.
- The site is free of vibrations and away from other equipment that can cause vibration, e.g. compressors.
- There is adequate clearance between the frame's top cap and ceiling. Starrett recommends at least 24 inches of clearance.
- The system is accessible for routine service. Much of the service is performed at the back of the machine. Allow at least three (3) feet of space on all sides of the frame.
- The electrical power source rating is within the voltage rating specified for the machines.
- The electrical power source is within 8 ft. (2.4m) from the system.
- The power cord to the tester and from the power source should be easily accessible, allowing a user to unplug the power cord immediately if necessary.

WARNING

- Never use extension cords with your system.
- The test site meets the system's environmental specifications.

4.4 INPUT POWER

Your FMS system has a self regulating power input module. There are no jumpers to set. Simply plug the power cord into a clear source of power.

IMPORTANT

Make sure the power source voltage is within the published frame specifications.

CAUTION

Use a 3-wire, grounded main power cable for the FMS frame and L2 Controller.

IMPORTANT

Make sure the power cord to the power entry connector, located on the back of the FMS frame is easily accessible so that power can be disconnected from the power source immediately if required.

4.5 CONNECTING SYSTEM COMPONENTS

This section will describe how to connect components to your FMS frame.

CAUTION

Electrical Hazard. Do not connect power cables when the power switch is in the ON position.



4.5.1 INSTALLING THE L2 CONTROLLER

The L2 Controller attaches to the FMS column. The column is fitted with a ball joint. The L2 Controller attaches to a plate with a ball joint. An adjustable RAM arm attaches to both ball joints. The RAM arm lets you position the L2 Controller for maximum comfort and easy operation.



4.5.2 INSTALLING BASE CLEVIS ASSEMBLY

Your FMS frame's base has a metric threaded M6 or M12 hole. The Base Clevis is used to fit your testing fixtures. The Base Clevis has either an M6 or M12 male threaded screw connector. To attach the Base Clevis, screw the Base Clevis into the base hole.



4.5.3 INSTALLING FLC LOAD CELL SENSOR

The FLC load cell sensor connects to the FMS frame's crosshead. The FMS500 has a hole clearance that accepts an M6 hex screw and locking washer. The FMS1000, FMS2500 and FMS5000 are supplied with two bushings that fit into a hole the crosshead. The bushing are sized to fit an M6 or M12 hex screw and locking washer. Your load cell sensor will dictate what size screw is necessary to attach your sensor to the crosshead.



CAUTION

Starrett recommends that you turn power on your FMS Series system OFF when connecting your load cell sensor.

4.5.4 INSTALLING LOAD CELL CLEVIS ASSEMBLY

The Load Cell Clevis is the same as the Base Clevis. It attaches to the load cell sensor's female metric thread.

IMPORTANT

Exercise caution when threading the clevis onto your load cell sensor. Avoid applying excess torque that can damage the sensor's internal electronic circuit.

4.5.5 INSTALLING TESTING FIXTURE

Test fixtures feature a 15.9mm diameter attachment. This attachment slides onto the Base Clevis and Load Cell Clevis.

The test fixture is secured to the Clevis adapter using a 8mm grip pin. Both Clevis devices include two (2) locking rings. Use the rings to tighten the clevis to the sensor, base and test fixture.



4.6 INSTALLING ANTI-SKID MOUNTING CLIPS

Anti-skid mounting clips are supplied with the FMS1000 and FMS5000 Series test frames and may be used to permanently secure the frame to the desktop. These clips are recommended per IEC 61010 safety standards

- Remove the four (4) rubber mounting feet on your FMS frame.
- Place a mounting clip onto each of the threaded feet.
- Screw the feet back into the FMS base.
- Arrange the mounting clips so that each one extends outward away from the FMS base.
- Use an appropriate screw to affix the mounting clip to the work surface where the FMS will be used. Make sure that there is no movement of the machine and that the machine is tightly held in contact with the work surface prior to operation.

IMPORTANT

You should check that the machine is secured tightly against the work surface prior to each use.

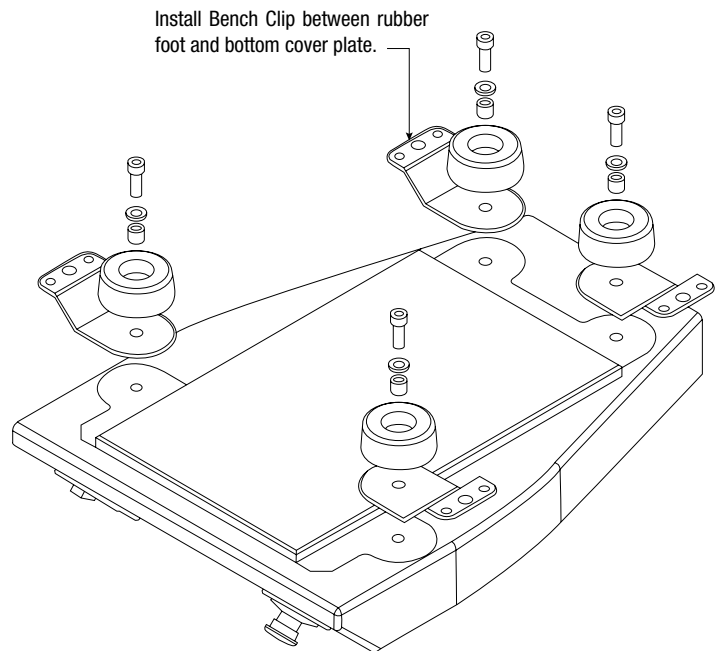

Remove the mounting feet on your FMS frame and insert a mounting clip onto each foot. Re-thread the mounting feet into the base. Use all four mounting clips to properly affix the machine to the surface.

Secure the FMS by screwing the mounting clips into the work surface. Make sure that the machine is tightly connected and that there is no amount of frame movement on the surface prior to use.

5.0 SYSTEM CONTROLS

This section will describe the controls used with your FMS Series force measurement system to perform tests.

5.1 FMS TEST FRAME

The majority of controls for your FMS Series force measurement system are located on your FMS Series frame. These are described in the following sections.

5.1.1 EMERGENCY STOP SWITCH

The Emergency Stop Switch is located on the left-hand side of the FMS base. This switch interrupts power to the electrical drive system and brings the system to a stop as quickly as possible.

IMPORTANT

Engaging the Emergency Stop Switch does not remove power to the system. When the Emergency Stop Switch is engaged, power to the drive system is interrupted. No crosshead movement is possible.

When operated, the Emergency Stop Switch locks down into a closed position. The crosshead movement is disabled.

To reset or disengage the Emergency Stop Switch, press down and turn counter-clockwise. The switch will release upwards and return power to the drive system.

5.1.2 POWER SWITCH

The main power switch for your FMS Series frame is located on the back of the machine.

- Connect the machine to a source power outlet.
- Turn the On/Off switch to the ON position to operate.
- When your machine is not being used, turn the power switch to the OFF position.

5.1.3 JOG SWITCH

The Jog Switch lets you move the crosshead UP and DOWN. When using the Jog Switch, pressing the switch cause the crosshead velocity to increase from zero to full velocity (60 inches per minute / 1525mm per minute) in about 3 seconds. You may restrict the maximum velocity using the L2 Controller Motion Settings.

JOG UP - press the up portion of the switch to cause the crosshead to move upward. Release the switch to stop motion.

JOG DOWN - press the down portion of the switch to cause the crosshead to move downward. Release the switch to stop motion.

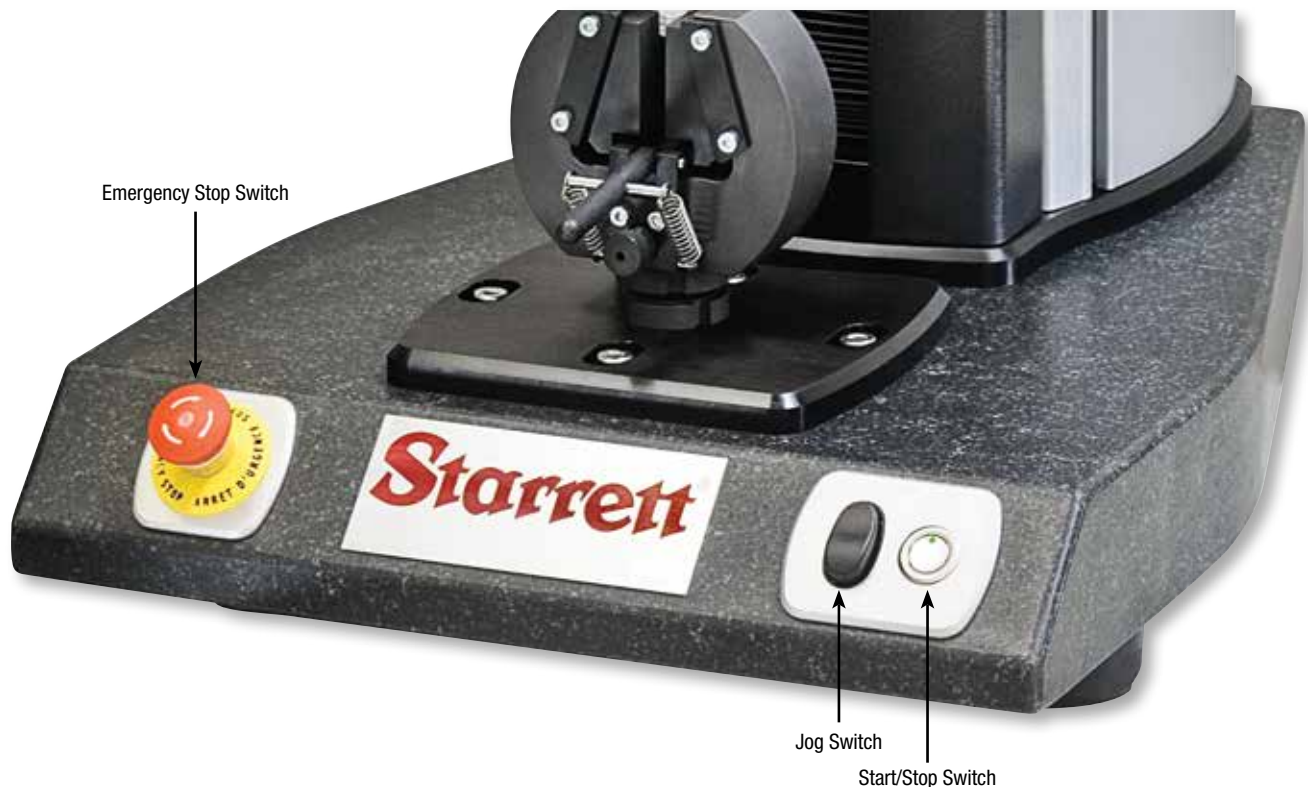

5.1.4 TEST START/STOP SWITCH

Use the START/STOP Switch to start or stop a test. An LED on the START/STOP Switch illuminates to show that a test is in progress or that the tester is ready to perform a test.

IMPORTANT

Starrett recommends that you use the START/STOP Switch to start or stop your test setups.



5.1.5 TRAVEL LIMIT SWITCHES

Limit Switches are located on the side of the column and used to restrict crosshead travel. Position your upper and lower travel limit switches so that they are approximately 2-3 inches above/below where your crosshead will stop during a normal test procedure. These travel limits will stop the crosshead should the crosshead come into contact with one of the limits.

5.2 L2 CONTROLLER

This section will describe the main operational controls available on the L2 Controller with L2 software for force measurement.

5.2.1 POWER SWITCH

The power switch is located on the side of the L2 Controller. The L2 Controller should be connected to its own power source using a 3-wire grounded power cord. The power switch is pressed to turn power to the tablet computer ON or OFF.

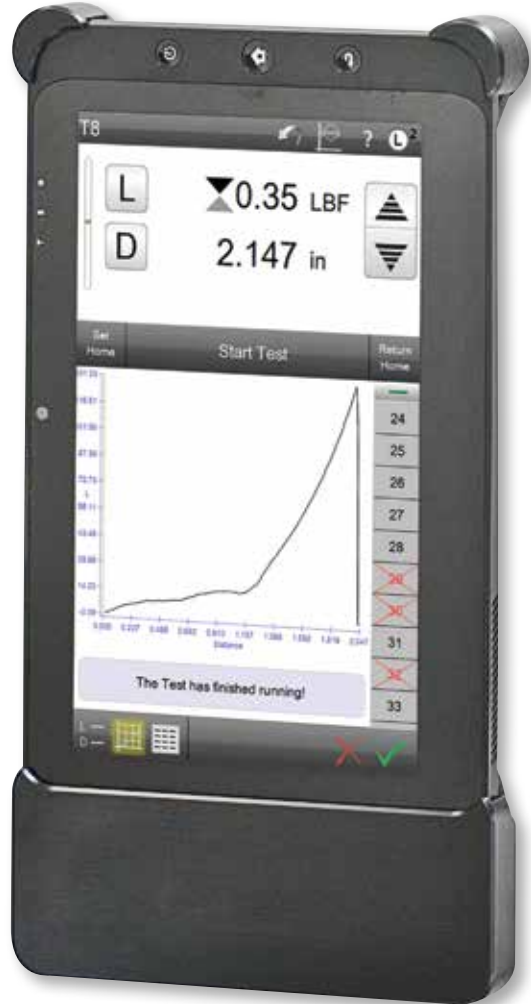

5.2.2 START/STOP TARGET

The L2 Controller's main operating displays have a control section. The control section is located beneath the digital read out section where the measured load (L) or distance (D) are displayed.

The control section will display START TEST when a test is ready to be performed. It will display STOP TEST when a test is being performed. You may control a test's START or STOP using the touch target in the control section, however, Starrett recommends that you use the START/STOP button since continued pressing on the L2 Controller display may cause permanent scratching due to finger nails.

IMPORTANT

The L2 Controller is a touch screen operated tablet personal computer. Always touch targets using the pad of a finger tip rather than the finger nails. Touching targets with the finger nail can scratch the display surface.

During an active RUN, the Limit setpoint is displayed. In this example the tension load limit of 38N is shown above the currently measured load of 14.130N.

The screenshot shows the L2 Controller interface for a test titled "My Load Test". At the top, there are icons for home, settings, and a status bar showing "S 50" and "L 2". The main display area is divided into several sections:

- Top Section:** Displays "L" (Load) and "D" (Distance). The current load is 14.130 N, and the distance is 0.556 in. A limit setpoint of 38.000 N is shown above the current load.
- Control Section:** A large "Stop Test" button is centered.
- Data View:** A box titled "Results for last run" shows "L 38.000 N" and "D 1.496 in".
- Status Block:** A bar at the bottom shows "Pull", "L_{lim} = 38.000 N", "S = 20.000 in/min", and "2".
- Runs List:** A vertical list on the right shows the number "1".
- View Toggle:** At the bottom left, there are icons for "L" (Data View) and "D" (Graph View), with "L" being highlighted.

The Data View shows the results from the previous test RUN (Run 1).

The Overlay target is used during the Graph View. This allows you to select multiple RUNS for graphing together.

The Runs List shows the current number of Runs performed. In this example, we are running Run 2. Run 1 is listed.

The Status Block reports the current step being performed for the test setup. Shown is the test direction (tension/pull), the Load Limit (38.000N) and the Test Speed (20.000 in/min). The Step Number (2) is also displayed.

This symbol represents the Data View. It is highlighted to show that you are viewing the Data View format. The other symbol represents the Graph View. You may also perform a test Run while in the Graph View.

6.0 USING YOUR FMS SYSTEM

The following sections will provide you with general guidelines for using your FMS Series force measurement system. Starrett recommends that you received professional training by an authorized Starrett Representative prior to operating your testing system.

6.1 FLC LOAD CELL SENSORS

The FLC load cell sensors are precision instruments engineered to be used with your FMS Series frame and L2 Controller. FLC load cell sensors are precision resistance instruments with a measurement accuracy of better than 0.1% full scale.

Starrett offers three model FLC load cell sensors: Economy, Environmentally Sealed and Premium. All sensors are supplied with a Certificate of Calibration traceable to NIST. Sensors may be calibrated on-site by your authorized Starrett Representative in accordance to ASTM E4 or ISO 7500/1.

IMPORTANT

- Starrett recommends that you allow your load cell sensor a warm-up period of 15 minutes prior to use. This warm-up time allows the sensor's internal electronics to stabilize.
- FLC load cells should not be used to measure load below 2% of their rated full scale capacity per ASTM E4.

It is best to use a load cell that operates in the mid-range of the sensor's full scale capacity thus allowing protection from overloading your sensor if operated at the high-end of the capacity.

"ECONOMY" SERIES

MODEL	CAPACITY	SAFE OVERLOAD	FS DEFLECTION	THREAD
FLC-50E	50N / 11 lbf / 5 kgf	150%	0.003"	M6 x 1-6H
FLC-100E	100N / 22 lbf / 10 kgf	150%	0.003"	M6 x 1-6H
FLC-200E	200N / 44 lbf / 20 kgf	150%	0.003"	M6 x 1-6H
FLC-500E	500N / 112 lbf / 50 kgf	150%	0.004"	M6 x 1-6H
FLC-1000E	1000N / 225 lbf / 100 kgf	150%	0.006"	M6 x 1-6H
FLC-2000E	2000N / 450 lbf / 200 kgf	150%	0.006"	M12 x 1.75-6H
FLC-5000E	5000N / 1124 lbf / 500 kgf	150%	0.005"	M12 x 1.75-6H

"SEALED" SERIES

MODEL	CAPACITY	SAFE OVERLOAD	FS DEFLECTION	THREAD
FLC-500	500N / 112 lbf / 50 kgf	150%	0.004"	M6 x 1-6H
FLC-1000	1000N / 225 lbf / 100 kgf	150%	0.006"	M6 x 1-6H
FLC-2KN	2000N / 450 lbf / 200 kgf	150%	0.005"	M12 x 1.75-6H
FLC-5KN	5000N / 1124 lbf / 500 kgf	150%	0.005"	M12 x 1.75-6H

"PREMIUM" SERIES

MODEL	CAPACITY	SAFE OVERLOAD	FS DEFLECTION	THREAD
FLC-5P	50N / 11 lbf / 5 kgf	1000%	0.014"	M6 x 1-6H
FLC-10P	100N / 22 lbf / 10 kgf	1000%	0.012"	M6 x 1-6H
FLC-25P	200N / 44 lbf / 20 kgf	1000%	0.011"	M6 x 1-6H
FLC-50P	500N / 112 lbf / 50 kgf	1000%	0.009"	M6 x 1-6H
FLC-100P	1000N / 225 lbf / 100 kgf	1000%	0.007"	M6 x 1-6H
FLC-250P	2000N / 450 lbf / 200 kgf	1000%	0.006"	M6 x 1-6H



FLC Economy Load Cell Sensor

6.2 PINCH LOAD

The Pinch Load option is a feature that helps prevent a user from pinching fingers when controlling the test frame manually in the compression direction. The maximum load value than may be entered is 50N (11lbf). During a manual movement of the crosshead in a downward direction, if a load is detected at the Pinch Load value, the crosshead with automatically decelerate to a full stop. The L1 software will display a warning message that the crosshead has stopped due to a Pinch Load condition.

If users do not want to use Pinch Load, the value in Pinch Load should be zero or null.

WARNING

Test frames should be operated by trained and authorized personnel only. Operation of the test frame should be performed according to the user's company safety procedures first and always. Proper operation of the test frame is the responsibility of the user.

CAUTION

- Operating the test frame manually should be performed at low speeds.
- Never operate the test frame without the L1 software or the DFC force gage connected to the test frame and measuring load.

NOTE

- When a pinch load is detected, the crosshead will not move downward. The crosshead can only be moved upward.
- The Pinch Load option REQUIRES that some form of load measurement is being performed using L1 software or a DFC force gage. If there is no load detection, the Pinch Load function is not possible.
- The maximum load value that may be entered into the Pinch Load option is 50N (11lbf).

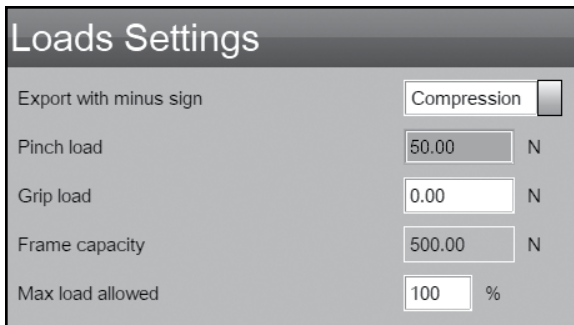

Shown: Load Setting Options

6.3 L2 CONTROLLER

Your L2 Controller is your primary interface for operating your FMS force measurement system. The L2 software, resident on your L2 Controller provides you with methods for performing all common force measurement testing procedures.

For information on using your L2 Controller and software, please refer to the Quick Test User Guide and the Test Builder User Guide.

6.4 TEST FIXTURES

Starrett offers a variety of testing fixtures engineered to provide secure holding of your sample under test. Starrett can assist you in selecting the correct fixture for your testing application.

Test fixtures should be selected based on the material being tested and the anticipated load measurements that you expect. Test fixtures have a load capacity rating, therefore, always make sure that the rated load for your fixture is well within the anticipated load measurement for your sample.



FMS500 with L2 Controller and optional Load Cell Sensor and Wedge-action Test Fixture

7.0 OPERATION

The following sections will provide you with basic guidelines for operating your FMS Series force measurement system.

7.1 SYSTEM STARTUP

Prior to starting your FMS Series force measurement system, ensure that you understand the operating and safety features of your system. Also, always verify operating controls prior to use.

- Ensure that all cables are properly installed and securely connected.
- Turn power to the FMS frame and L2 Controller to the ON position.
- Allows your system to warm-up by allowing the system to stabilize after a 15 minute warm-up period.
- Launch the L2 Controller software.
- Create and perform your force measurement testing with exceptional ease and accuracy.
- Contact your Starrett Representative for assistance if needed.



Crosshead Travel Limit

7.2 SETTING CROSSHEAD TRAVEL LIMITS

Your FMS frame has two crosshead travel limits located on the side of the column. These limit switches are intended to protect the crosshead from traveling too far in either direction.

CAUTION

Do not use the limit stops to end a test.

The travel limits are not intended to be an "end of test" condition used to conclude a test.

IMPORTANT

Always set the crosshead travel limits at the desired location before starting a test. Failure to set these crosshead limits may result in injury due to unexpected crosshead motion and damage to your load cell sensor and testing fixture.

Set the upper and lower crosshead travel limits after you have established the crosshead starting position for your test, but before you begin testing.

Each travel limit operates as an adjustable block. Each limit has a thumbscrew that you tighten and release by hand. Loosen the thumbscrew so that the limit moves freely up or down on the column. Slide the limit up/down on the column to the desired position. Both limits should be positioned just beyond the normal travel distances for your test. When the crosshead reaches the maximum pre-set travel, the limit switch actuator contacts one of these stops. This causes the crosshead to stop its motion.

IMPORTANT

Your L2 software also contains travel protection for your crosshead. These should be used in addition to your mechanical crosshead travel limits. Within the L2 software, all Quick Test setups and your Tension and Compression stages, contain CONDITIONAL SETTINGS. Included in these settings is the ability to stop the crosshead when a distance limit is reached.

Should the crosshead contact either the upper or lower travel limit, the test will stop and the crosshead will stop moving. If this happens, use the jog switch on the your FMS frame base to move the crosshead off the limit stop. Press the DOWN direction on the jog switch to move the crosshead off the upper limit. Press the UP direction on the jog switch to move the crosshead off the lower limit. The crosshead motion arrows on your L2 Controller will display and animate when the crosshead is in motion.

7.3 SETTING GRIP PROTECTION

Grip protect is an L2 software feature. This allows you to set a maximum load that protects you from accidentally overloading your testing fixture. With the grip protection feature, you specify a maximum load. If this load is achieved during a test, the test will abort and the crosshead will stop.

NOTE

Use the Grip Protection feature within your L2 Controller and software to protect your test fixture for inadvertent overloading.

Use to assign a "sign" to either tension or compression. Normally, compression is a negative number.

The Grip Load is used to protect your gripping fixture from damage due to overloading. Set the Grip Load to a load capacity that is less than the capacity of the gripping fixture. If this load is achieved, the crosshead will stop and the test will abort.

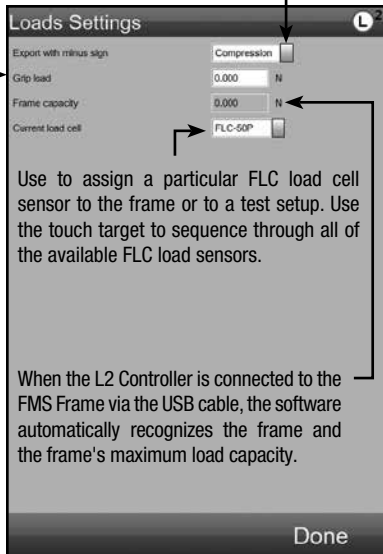

Use to assign a particular FLC load cell sensor to the frame or to a test setup. Use the touch target to sequence through all of the available FLC load sensors.

When the L2 Controller is connected to the FMS Frame via the USB cable, the software automatically recognizes the frame and the frame's maximum load capacity.

7.4 LOAD CELL PROTECTION

Your FLC load cell sensors have mechanical overload protection. The Economy and Sealed Series sensors have mechanical overload protection up to 150% of the sensor's rated capacity. The Premium Series have protection up to 1000% of the sensor's rated capacity.

The L2 Controller's load bar graph and sensor symbol (on the header) will display a color to depict the amount of load being measured by the sensor relative to the sensor's rated capacity. When the color YELLOW is being displayed, you should use caution. When the color RED is being displayed, you should use extreme caution and be prepared to stop your test.

When your sensor is measuring between 0 and 74% of its rated capacity, the bar graph will display GREEN.

When your sensor is measuring between 75% and 90% of its rated capacity, the bar graph and sensor symbol will display YELLOW.

When your sensor is measuring above 75% of its rated capacity, the bar graph and the sensor symbol will display RED.

IMPORTANT

- Observe the load bar graph indicator and sensor symbol when performing a test. If the bar graph and sensor symbol display RED, be prepared to stop the test to protect your load cell sensor from an overload condition.
- Your L2 software also contains load protection for your load cell sensor. Within the L2 software, all Quick Test setups and your Tension and Compression stages, contain **CONDITIONAL SETTINGS**. Included in these settings is the ability to stop the crosshead when a load limit is reached. It is recommended that you use the Load Condition.

Shows the test mode (Tension) and the direction of crosshead travel.

Crosshead status arrows animate when the crosshead is moving and shows the direction of travel.

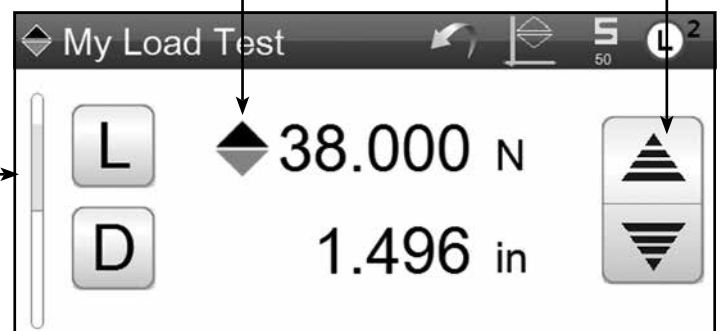

The Load (L) and Distance (D) targets. Press to zero the measured value being displayed.



7.5 STARTING A TEST

Before starting a test we recommend the operator perform the following pre-test checks:

- Verify that the system is properly installed and all preparation is complete.
- You are using a calibrated FLC Series load cell sensor.
- You have properly set the upper and lower crosshead travel limits.
- You have set appropriate CONDITIONAL SETTINGS in your L2 Controller for Distance and Load Limits.
- Verify that your test setup parameters are set in accordance with your testing requirements.
- Your operator has reviewed the manual for the control system and L2 Controller and are familiar with all safety and operating features.

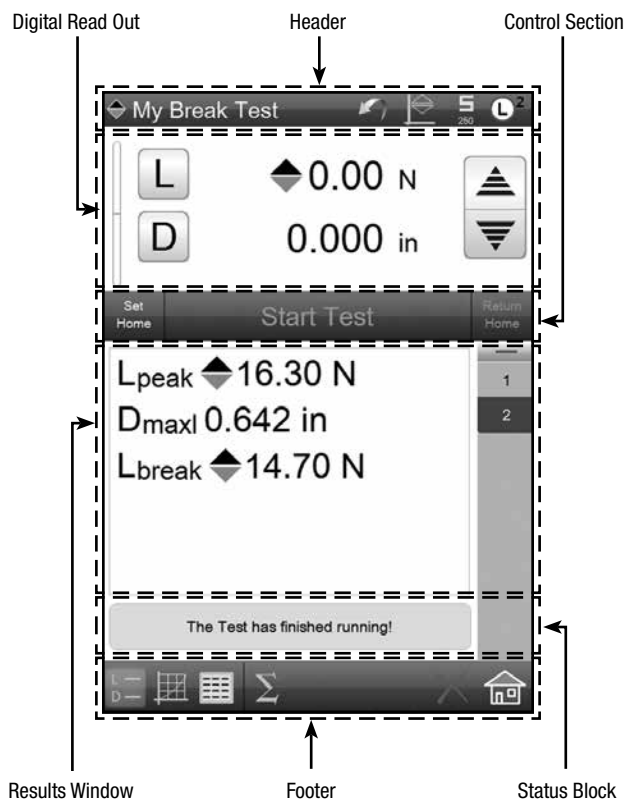

7.6 STOPPING A TEST

You may stop a test using hardware controls on the FMS frame and software controls on your L2 Controller.

7.6.1 EMERGENCY STOPPING

The Emergency Stop switch is a large, round, red button switch with LED. It is located on the front left-hand side of your FMS frame's front panel.

Press this button to stop the test as soon as possible when a condition develops that could compromise the safety of the operator or that risks damage to your hardware.

To release the Emergency Stop, press and turn clockwise. The Emergency Stop switch should return to its OFF position.

7.6.2 USING START/STOP BUTTON

The START/STOP button switch is located on the front right-hand side of your FMS frame's front panel. This switch has an LED indicator that illuminates GREEN or RED. When a test is in operation and the crosshead is active, you may stop a test by pressing the START/STOP button switch.

IMPORTANT

The START/STOP button switch is intended to be the PRIMARY method to use to Start and Stop a test.

7.6.3 USING START/STOP TARGET

Your L2 Controller main operating displays contact a Control section. Within this control section is a touch target that can display START TEST or STOP TEST. When a test is ready to be performed, you may touch the START TEST target to initiate a test setup. During a test, while the crosshead is active, you may stop a test by pressing the STOP TEST target.



Jog Switch and Start/Stop Switch

8.0 MAINTENANCE

Your FMS force measurement tester is a precision instrument designed to perform accurate force measurement testing for a variety of applications. Starrett recommends that you have your system maintained by a factory-trained Starrett Service Representative at least annually. If your system is used in a more demanding application or in a harsh environment, it may be wise to have maintenance performed more frequently.

CAUTION

- Dangerous voltages and internal rotating machinery inside the machine may cause bodily injury or damage to the equipment.
- Personnel not trained in the service of Starrett force testing systems should not remove the covers to gain access to any internal components within your system.

8.1 PREVENTIVE MAINTENANCE

Starrett recommends that you periodically inspect, clean and lubricate your FMS force measurement system.

8.1.1 DAILY MAINTENANCE CHECKS

Starrett recommends that you perform daily maintenance checks on your FMS force measurement system prior to operation. These checks should include the following:

- Emergency Stop Switch operation
- Jog Switch operation
- Start/Stop Switch operation
- Crosshead travel limit operations
- L2 Controller Start/Stop operation
- Cable and Power Cord connections

8.1.2 AUTHORIZED FACTORY MAINTENANCE

Starrett recommends that you have an authorized Starrett Service Representative perform at least an annual maintenance on your FMS force measurement system. This maintenance will include:

- Inspection and servicing any loose fittings
- Check operation of crosshead travel limits
- Check operation of all cables
- L2 Controller operation
- Software updates (if needed) for your L2 Controller
- Verification of crosshead travel speed
- Verification of encoder distance accuracy
- Verification and re-calibration of load cell sensor(s) to ASTM E4 standard

8.1.3 CLEANING

Starrett recommends that your FMS force testing system be cleaned weekly or more often if operated in a non-laboratory environment.

WARNING

- Disconnect power to your FMS force measurement tester and the L2 Controller before cleaning these instruments.
- Use a moist, lint-free cloth with very mild detergent (if required) to clean the outside surfaces of your FMS Series force measurement system.
- Read the Care and Cleaning instructions for the L2 Controller and follow the manufacturer's recommendations.

CAUTION

- Do not clean with solvents or abrasive cleaning agents.
- Do not apply excessive amounts of detergent cleaning agents. Exercise caution when using water or mild cleaning detergents to prevent fluids from getting into electrical contacts or rotating machinery.
- Do not use oil to lubricate.
- Use low-pressure air to remove dust and debris from tester surfaces. Always protect the column and internal machinery components from dust and debris from getting inside the column.

8.1.4 LUBRICATION

Lubrication of the internal ball screw should be performed by authorized Starrett Service Representatives only.

8.2 MAINTENANCE PROCEDURES

These general maintenance procedures may be followed for performing the following maintenance checks. These procedures do not require an authorized Starrett Service Representative.

8.2.1 TRAVEL LIMITS

- Verify that power to your system is ON.
- Use the jog switch to manually position the crosshead to a location that is approximately at the center position of the column.
- Position the Upper crosshead travel limit to approximately 3 inches above the crosshead's center column position. Make sure the crosshead travel limit is tightened.
- Position the Lower crosshead travel limit to approximately 3 inches below the crosshead's center column position. Make sure the crosshead travel limit is tightened.

Use the UP jog switch to slowly move the crosshead upward until it comes into contact with the Upper limit. The crosshead should stop automatically. If it does not, contact your Starrett Service Representative immediately.

Use the DOWN jog switch to slowly move the crosshead downward until it comes into contact with the Lower limit. The crosshead should stop automatically. If it does not, contact your Starrett Service Representative immediately.

8.2.2 EMERGENCY STOP

- Verify that the Emergency Stop Switch is in the ON position.
- Press the jog switch. The crosshead should not move since the Emergency Stop is in the down (ON) position.
- Press and release the Emergency Stop Switch so that the switch is UP and in the OFF position.
- Press the jog switch. The crosshead should move freely.



8.2.3 FUSE REPLACEMENT

WARNING

Electrical Hazard. Make sure to shut all power to your FMS force measurement system to OFF. Dangerous voltage may cause personal injury.

- Turn the power switch on the back panel of the FMS frame to the OFF position.
- Disconnect the power cord from the power source.
- Replace the fuse with the same type and size as the original.
- Remove the protective cap that covers the fuse compartment.
- Grasp and remove the fuse holder.
- Remove the fuse.
- Install a new fuse into the holder. The replacement fuse needs to be the factory-specified type and rating as original. An incorrect fuse may damage the electrical circuits inside your machine.
- Re-insert the fuse holder.
- Place the protect cap back onto the fuse compartment.
- Reconnect the power cable.
- Turn power to the system ON by placing the power switch in the ON position.

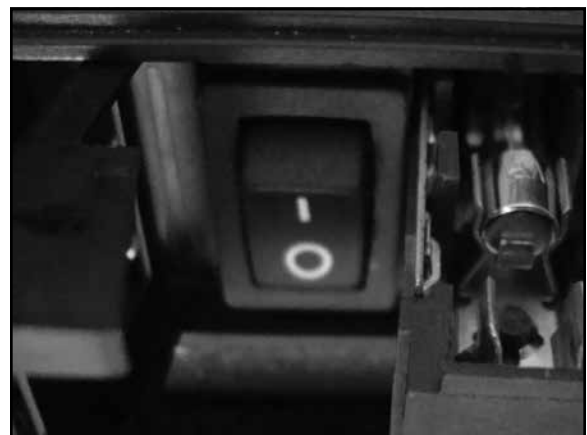

NORTH AMERICA
WWW.STARRETT.COM
ATHOL, MA, USA, 01331-1915

EUROPE & ASIA
WWW.STARRETT.CO.UK
JEDBURGH, SCOTLAND, TD8 6LR

SOUTH & CENTRAL AMERICA
WWW.STARRETT.COM.BR
13306-900, ITU, SP, BRASIL
CNPJ 56.994.700/0001-01

CHINA
WWW.STARRETT.COM.CN

USER MANUALS AVAILABLE ONLINE
AT STARRETT.COM

Starrett.com