

# Starrett®

PKG08815- QRGMTL330

**TRUST IS IN THE NAME**

Quick Reference Guide

**READ THIS MANUAL BEFORE USING THE INSTRUMENT**

**ANTES DE UTILIZAR EL INSTRUMENTO,  
LEA ATENTAMENTE ESTE MANUAL**

**LIRE CE MANUEL AVANT D'UTILISER L'INSTRUMENT**

**LEIA ATENTAMENTE ESTE MANUAL ANTES  
DE UTILIZAR O INSTRUMENTO**

**使用仪器前请阅读本操作手册**

**DIESES HANDBUCH VOR DER VERWENDUNG  
DES MESSGERÄTS LESEN**

**LEGGERE ATTENTAMENTE QUESTO MANUALE PRIMA  
DI UTILIZZARE QUESTO STRUMENTO**

# **Starrett<sup>®</sup>**

## **MTH-330 MANUAL TESTER**

### **QUICK REFERENCE GUIDE**

# TABLE OF CONTENTS

---

	PAGE
Introduction	8
Principle of Operation	8
Set Up for Use	8
Using Fixtures	8
Mounting Force Gage	8
Performing a Test	9
Using the Optional Digital Scale	9
Using the Optional Legs for Horizontal Operation	10
Horizontal Mounting Kit (p/n MLX-26030)	10
Optional Accessories	11
Force Gage Adapter Kits	11
Dimensions	12

---

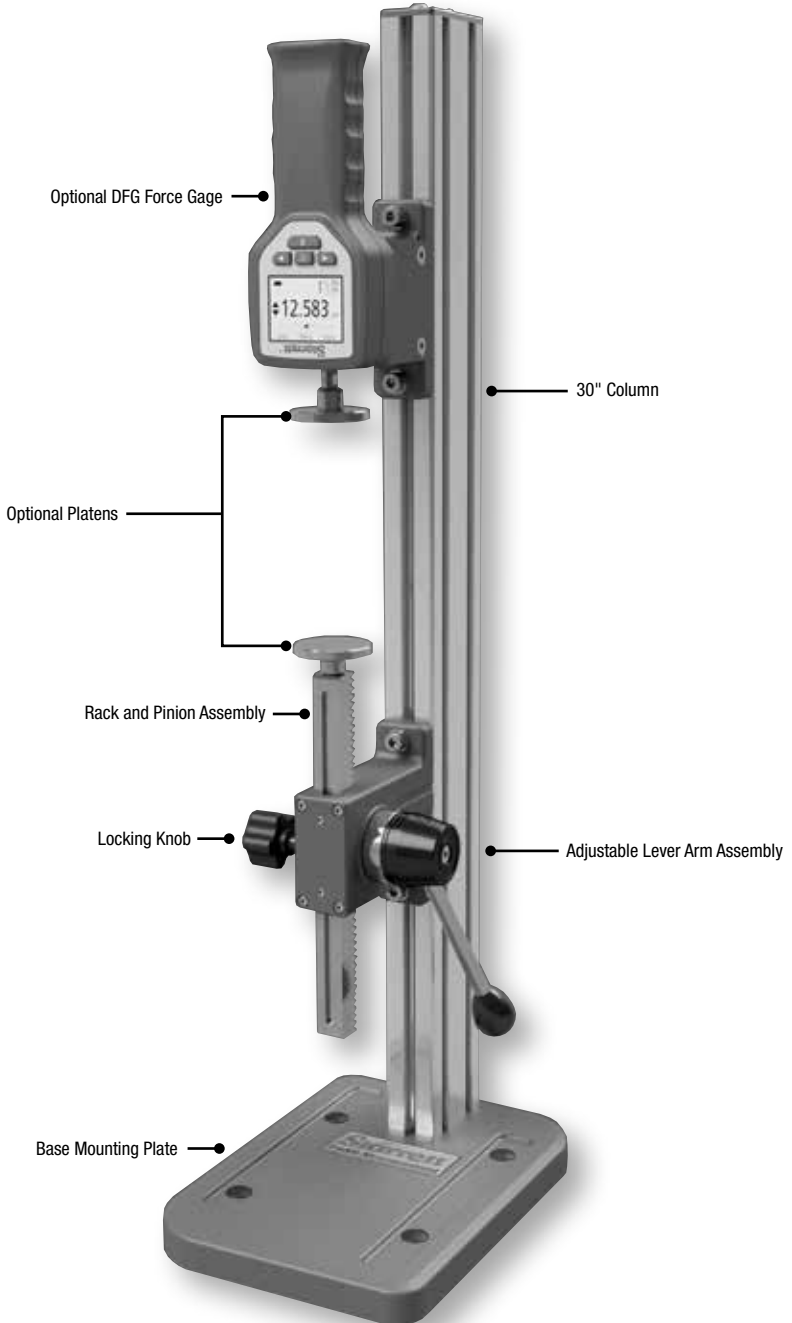



# MTH-330 MANUAL TESTER



**THIS IS A STARRETT QUICK REFERENCE GUIDE FOR THE MTH-330 MANUAL TESTER. ALL SPECIFICATIONS IN THIS DOCUMENT ARE CORRECT AT TIME OF PRODUCTION AND ARE SUBJECT TO CHANGE. PLEASE CONTACT STARRETT FOR FURTHER INFORMATION.**

# ENGLISH

## INTRODUCTION

Thank you for choosing the MTL-330 Force Tester. The MTL-330 manual tester is designed for basic tension or compression force testing applications. The MTL-330 has a force capacity of 330lbf (1500N).

## PRINCIPLE OF OPERATION

Rotating the lever arm moves the rack and pinion assembly 3" (76mm) per revolution. The MTL-330 has a full 6" (152mm) stroke.

The DFC or DFG Force Gage mounts to the gage bracket. The gage bracket may be moved for longer or shorter sample lengths. The force gage measures the load as the rack assembly moves in either direction.

The rack and pinion assembly attaches to the column. It may be positioned anywhere along the column.

A locking hub is used to prevent backlash during testing. An optional digital scale assembly (p/n MTL-SCALE330) may be attached to provide high resolution deflection measurements.

## SET UP FOR USE

Locate the MTL-330 tester where there is sufficient clearance for testing and moving the lever arm.

You may permanently secure the base to the work bench using flat head screws. Use the four corner hole locations to secure to your work bench if desired. Remove the hole plugs to reveal the 0.25" clearance holes.

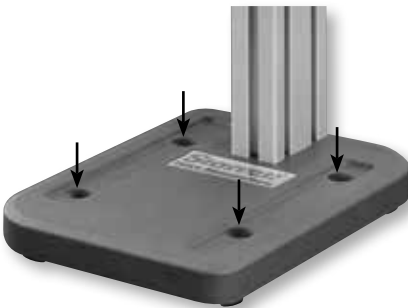

## USING FIXTURES

Affix the test fixture to the force gage's threaded stem and to the MTL-330 rack and pinion assembly. You may use either threaded test fixtures or fit the force gage and the test frame with the optional M6 clevis assembly (p/n SPK-CLEVIS-S). The force gage bracket has been designed to ensure correct centerline alignment.

## MOUNTING FORCE GAGE

The DFC or DFG Force Gage is mounted to the gage bracket using four M4 screws.

Position the force gage on to the gage bracket so that the load cell stem points downward. Use the force gage display "Flip option" to invert the display. Insert and torque the four M4 mounting screws through the gage mounting plate and into the force gage back panel. Torque the screws to no more than 8.7 in-lb (1.0 N-m).





### PERFORMING A TEST

Apply tension or compressive force on your sample by rotating the lever arm. As you rotate the lever, the rack and pinion assembly will move up or down. Rotating the arm clockwise will move the rack and pinion upward (compression) while moving counter-clockwise will move the rack assembly downward (tensile).

The locking hub should be tightened slightly to provide some friction to the movement so that the lever cannot reverse rotation (backlash) when under load.

### CAUTION

The lever arm can reverse direction unless secured by the locking hub. Use the locking hub to prevent backlash.



### USING THE OPTIONAL DIGITAL SCALE

The MTL-330 may be fitted with the optional digital scale (p/n MTL-SCALE330). The scale will display distance measurement for your test. For example, you can use the digital scale to measure and display spring deflection to determine the spring rate for a compression spring. The scale will measure either tension or compression distances.

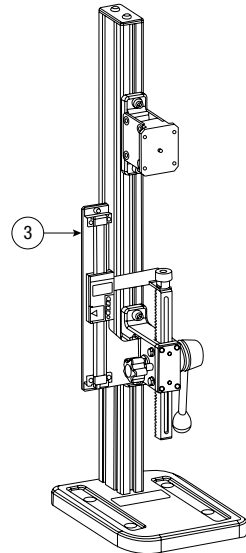
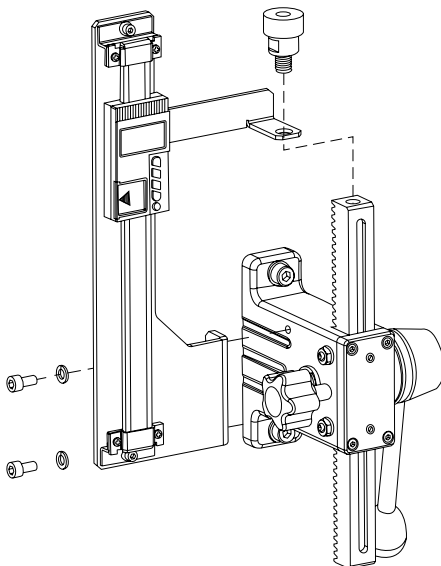

# ENGLISH

## USING THE OPTIONAL LEGS FOR HORIZONTAL OPERATION

You may fit the MTL-330 with optional mounting legs (p/n MLX-26030). This allows you to position the test frame horizontally on your work surface.

## HORIZONTAL MOUNTING KIT (P/N MLX-26030)

Includes two (2ea) mounting legs, an end cap (not shown) and all necessary mounting hardware. Replaces the standard baseplate for horizontal testing.

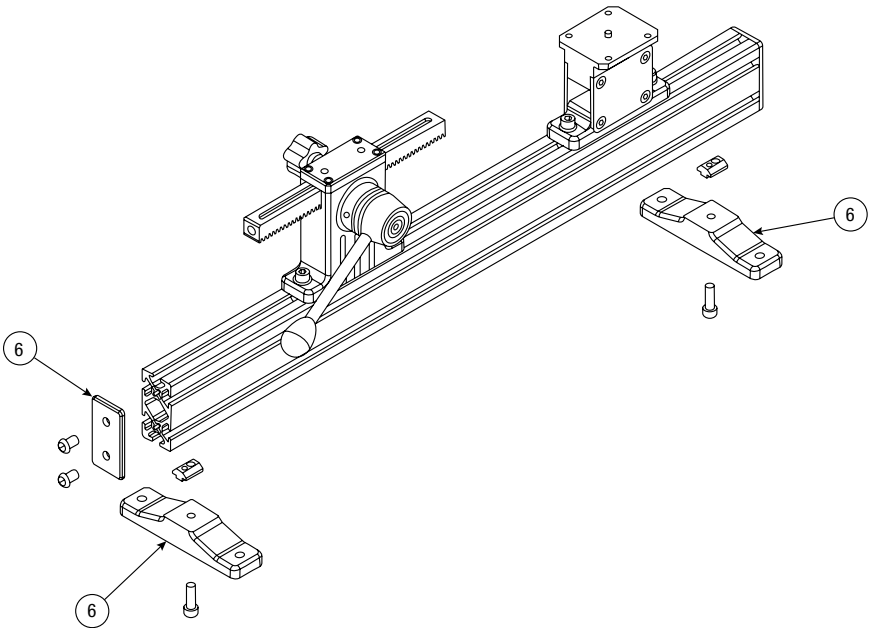
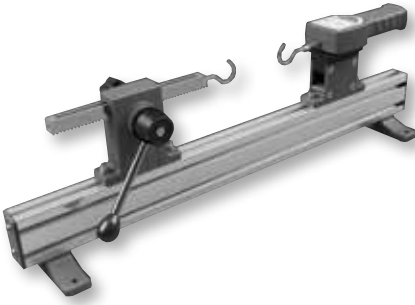

**OPTIONAL ACCESSORIES**

ORDER NO.	DESCRIPTION
MLX-PLATE-TS-100	Compression Plate, Steel, 100mm diameter
MLX-HOOK-L	M10 Hook Adapter, 330 lbf Load Capacity
SPK-CLEVIS-M	M10 Clevis Set, Stainless Steel, 330lbf
MTL-SCALE330	Digital Scale Assembly, MTL-330 only
MLX-26030	Mounting Legs, for horizontal testing
L1-Spanner	Spanner Wrench for Clevis Sets
MLX-PIN-S	Grip Pin, Stainless Steel

**FORCE GAGE ADAPTER KITS**

ORDER NO.	DESCRIPTION
SPK-FG-CHAT	Mounting Kit for Chatillon Force Gages
SPK-FG-MARK	Mounting Kit for Mark-10 Force Gages
SPK-FG-SHIM	Mounting Kit for Shimpo Force Gages
SPK-FG-IMAD	Mounting Kit for Imada Force Gages
SPK-FG-MECM	Mounting Kit for Mecmesin Force Gages

Please consult with your Starrett representative when ordering Force Gage Adapter Kits to ensure model compatibility.

# ENGLISH

## DIMENSIONS

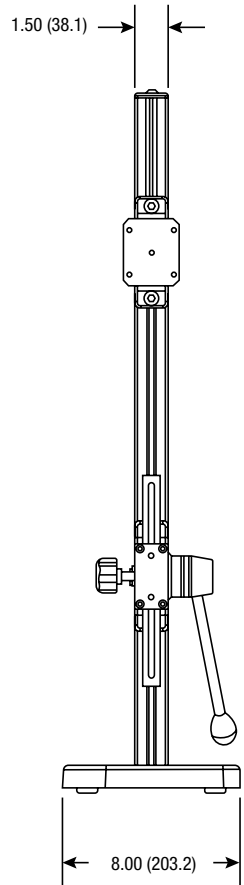
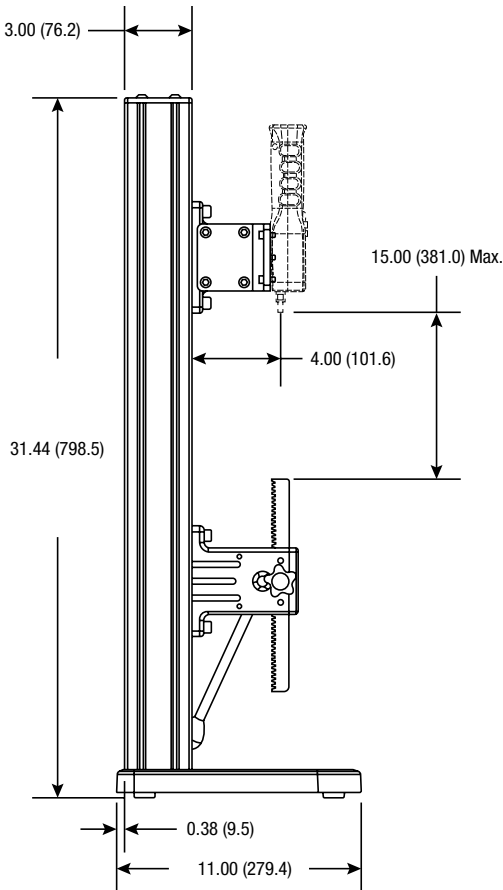
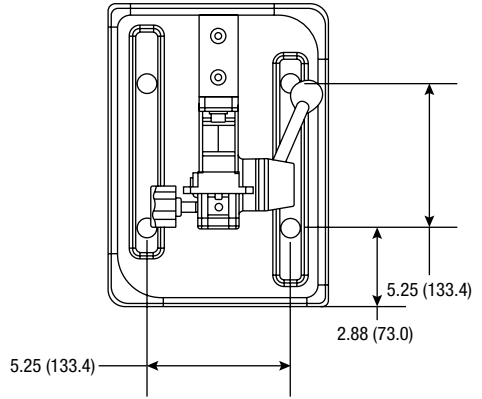

**NORTH AMERICA**  
**WWW.STARRETT.COM**  
**ATHOL, MA, USA, 01331-1915**

**EUROPE & ASIA**  
**WWW.STARRETT.CO.UK**  
**JEDBURGH, SCOTLAND, TD8 6LR**

**SOUTH & CENTRAL AMERICA**  
**WWW.STARRETT.COM.BR**  
**13306-900, ITU, SP, BRASIL**  
**CNPJ 56.994.700/0001-01**

**CHINA**  
**WWW.STARRETT.COM.CN**

**USER MANUALS AVAILABLE ONLINE**  
**AT STARRETT.COM**

[Starrett.com](http://Starrett.com)